



OPERATING INSTRUCTIONS

QUICK CLOSING VALVES APPLICATION

&

MAINTENANCE

MAY, 2020

WARNING

This manual is exclusive property DIKKAN, under copyright and any not authorized reproduction, in part or in total, shall be prosecuted.

Read and follow instructions carefully. Proper training and periodic review regarding the use of this equipment is essential to prevent possible serious injury and/or property damage. Shown products are according the current production. Dikkan reserves to modify product characteristics according technical evolution or customer special request. Verify if manual comply with used product.

trustable
brand
in the
world

CONTENTS

1. SAFETY TERMS	1
2. TECHNICAL FEATURES	1
3. DESCRIPTION	2
4. HOW TO MEASURE VALVES	3
5. QUICK CLOSING VALVE PART LIST	4
6. PROTECTION DURING STORAGE AND TRANSPORT	5
7. INSTALLATION	5
7.1 Installation Position	7
8. MAINTENANCE	8
8.1 Replace the Gasket	8
8.2 Metal to Metal Sealing	9
8.3 Hydraulic Oil	9
9. OPERATION	10
9.1 Operating Principles	10
9.2 Loading the Valve for Quick Closing	11
9.3 Closing of valve by the remote quick closing function	12
9.4 Closing of valve by the automatic release (in case of fire)	12
9.5 Closing valve with handwheel (optionally)	12
9.6 Change direction of release cylinder	13
9.7 Change direction of bonnet	13
10. RECYCLING	14
11. PRESSURE EQUIPMENT DIRECTIVE (97/23EC) AND CE MARKING	14
12. SAFETY REMARKS	14
13. PAINTING	14
14. TROUBLESHOOTING	15
15. WARRANTY	15
16. NOTES	16

1. SAFETY TERMS

The signal terms DANGER, CAUTION and NOTICE are used in this operating manual in the event of notices related special dangers, or for unusual information, requiring a special marking.



Danger refers that there is a danger of life and considerable damage in the event of non-compliance.



Caution refers that there is a danger of injuries and damage in the event of non-compliance.



Notice refers that attention is drawn to technical correlations/connections.

2. TECHNICAL FEATURES

Standard:	EN 12516
Face to Face:	Straight Form - EN 558 Series 1 (DIN 3202 F1) / Angle Form - EN 558 Series 8 (DIN 3202 F32)
Flange Dimension:	EN 1092-1, EN 1092-2, EN 1092-3
Material:	Ductile Iron, Cast Steel, Stainless Steel, Bronze
Type:	Release Cylinder
Application:	On board ships for fuel, oil etc.
Operation:	Hydraulic-Pneumatic-Mechanical Operated-Automatic release in case of fire

Pressure & Temperature Ranges

Ductile Iron, Bronze, Cast Steel, Stainless Steel	Working Pressure [bar]
Bore	80 °C
DN15-DN150	16
DN175-200	10



Valves must not be used at higher “pressure & temperature” than defined “working pressure & temperature”.

3. DESCRIPTION

Quick closing valves are designed for suddenly shut-off the flow in the pipeline. Quick closing valves are used in emergency situations and designed to serve simple and safety operations.

Quick closing valves have short dimensions so that easily fitted in narrow spaces. Quick closing valves are operated remotely by manual (wire arrangement), hydraulic or pneumatic activation.

General features of the quick closing valves are as follows;

- Bolted bonnet
 - Outside screw
 - Availability of special trim material
 - Flanged
 - Remote Control
 - Metallic seating surfaces
 - Rising handwheel
- Simple & Safety & Suddenly Operation

4. HOW TO MEASURE VALVES

To request or purchase the exact valve according to your needs, it is very important to provide pressure, temperature and medium information as well as dimensions as described below.

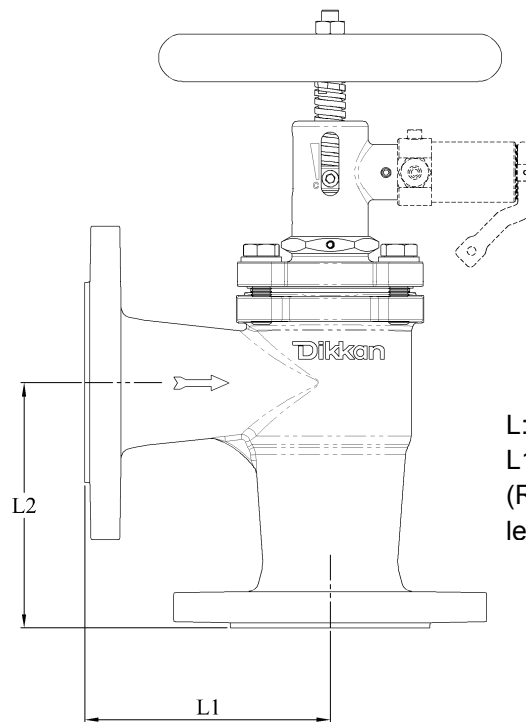
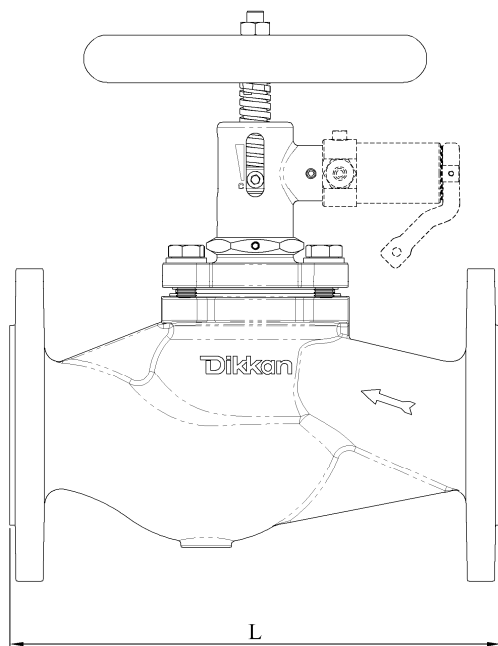

*Bonnet turned 90°

L: Face to Face Length
 L1 / L2: Center to Face Length
 (Raised face is included in length)

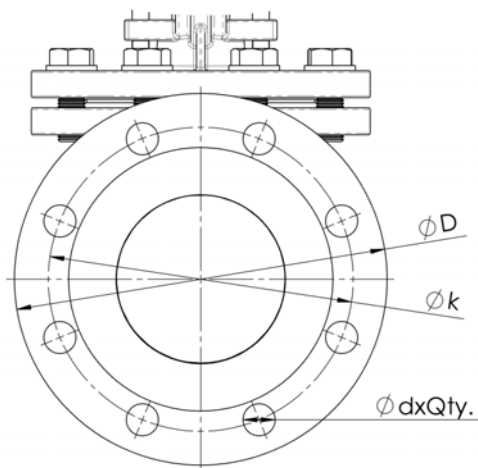

ØD: Outside Flange Diameter
 Øk: Hole Circle Diameter
 ØdxQty.: Diameter of Bolt Holes x Number of Bolt Holes

5. QUICK CLOSING VALVE PART LIST

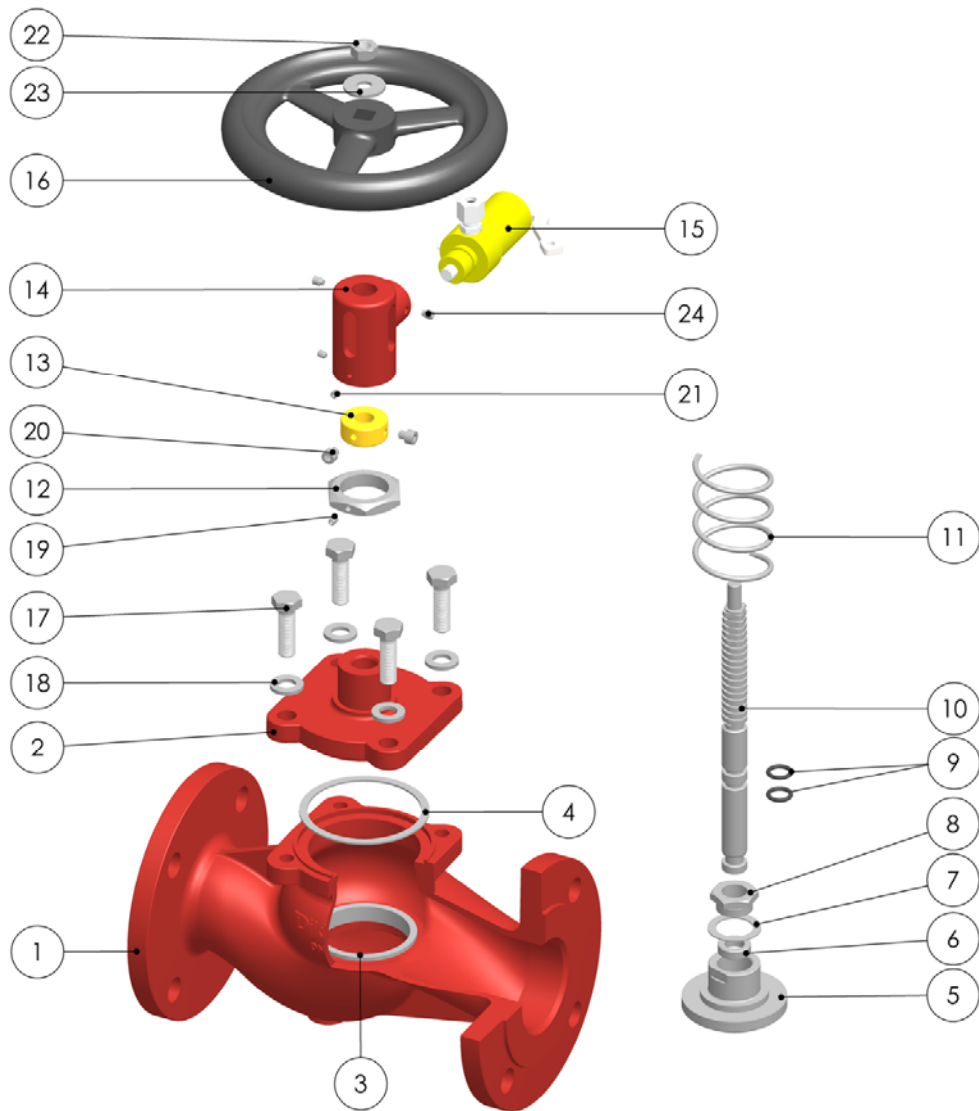

P. No	Part Name
1	Body
2	Bonnet
3	Body Seat
4	Gasket
5	Disc
6	Stem Core
7	Sheet
8	Disc Nut
9	O-ring
10	Stem
11	Spring
12	Bonnet Nut
13	Retainer Block
14	Cylinder Bonnet
15	Release Cylinder
16	Handwheel
17	Bolt
18	Washer
19	Setscrew
20	Hex Socket Head Bolt
21	Setscrew
22	Nut
23	Washer
24	Setscrew

All the information are only indicative data. DIKKAN has the rights to make changes without prior notice.

6. PROTECTION DURING STORAGE AND TRANSPORT

- Valves shall be stored in a closed area where they will not be exposed to direct sunlight.
- Valves shall be kept on pallets, avoiding any direct contact with the ground.
- Valves shall be protected from any external effects and damages in the storage area.
- Valves shall be protected from dust and dirt.
- Valves shall be kept with package until the installation to the pipeline (to prevent sweating in valve package, it is needed to prevent any sudden changes in temperature during the storage).
- Keep valves away from heat and flame sources in the storage area
- Protect the valve from excessive vibration during transportation.
- Optimum storage temperature should be between 5°C and 40°C.
- Unload all valves from wooden pallets to the ground carefully without dropping. When lifting, the valve should be secured by the body and never lifted by the trim.
- Condition of stored products shall be periodically verified.

7. INSTALLATION

- Pipelines and pipeline systems have to be installed in such way that no tensions from thermal expansion (or other) of the pipeline may have impact on the valves. This can theoretically even lead to breaks in the valves, causing danger from medium spills. DIKKAN offers suitable expansion joints for this purpose.
- Before installation, the pipeline must be cleaned off all dirt such as sand, dust, welding residues etc. Use strainers, in suitable sections of the pipeline, for future protection of the valve from dirt and foreign substances.
- Verify that the valve is suitable for the operating specifications of the medium (installation); such as maximum operating pressure, maximum operating temperature, corrosiveness and abrasiveness, etc.
- Verify that the distance between the flanges, where the valve will be connected, is equal to the length of the valve body.
- All protection devices for transport and storage have to be removed before installation.
- The arrow on the valve body must be in the same direction of the liquid flow.
- Valves shall be assembled to the pipeline in fully opened position.
- Use gaskets between the valve flanges and the counter flanges. The gasket should be suitable for operation conditions or maximum pressure/temperature ratings.
- The flanges which the valve will be assembled should be in the same axis and the flange surfaces should be parallel to each other.
- The bolting must be checked for correct size, length, material and that all connection flange bolt holes are utilized. Tighten the bolts and nuts in the crossover method shown in Fig. 1, to load the pipe and valve evenly and prevent stress on the joints. Finally tighten bolts to correct torque levels as recommended in Table 1. Do not overtighten.
- To avoid effects of weight and stress of the piping system to the valves, all piping systems should contain independent support mechanisms.
- After the installation process is completed, check the connections for leaks with water. Do not use the valve if it is leaking.
- During installation, prevent to damage the paint of the valve.

Table 1 Hex Head Bolt Max.Tightening Torque

Metric	M10	M12	M16	M20	M24	M27	M30	M33	M36	M39	M45	M52	M56	M64
(Grade 6.8, Steel) Torque (Nm)	37	64	158	310	535	787	1071	1455	1872	2431	3780	5850	7236	10852
(Grade 8.8, Steel) Torque (Nm)	50	87	210	412	711	1048	1422	1932	2481	3226	4992	7747	9650	14416
(Grade 70, Stainless Steel) Torque (Nm)	33	56	137	269	462	673	918	1237	1595	2057	3170	4913	6120	9130
(Grade 80, Stainless Steel) Torque (Nm)	43.5	75	183	359	617	897	1224	1648	2126	2743	4227	6550	8160	12174

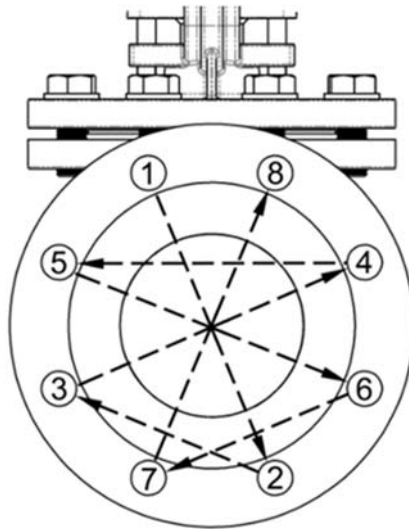
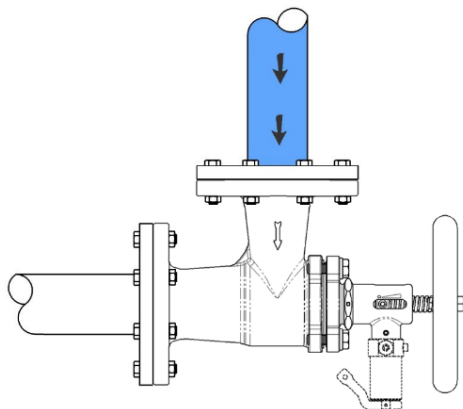
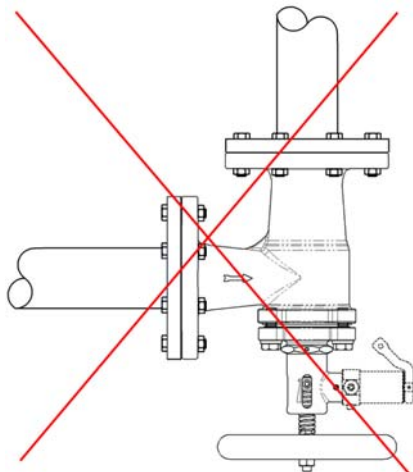
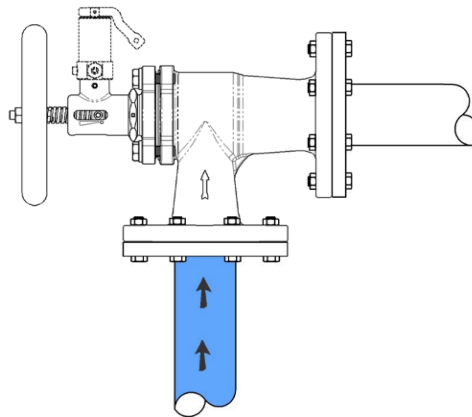
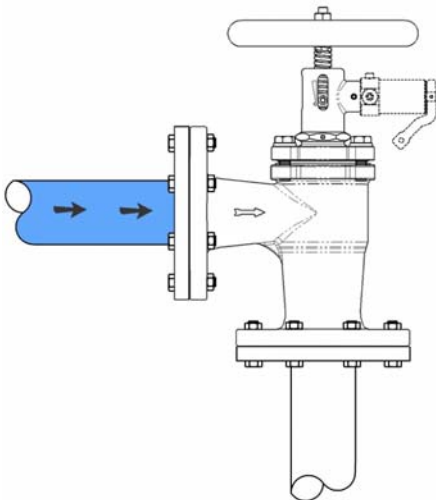
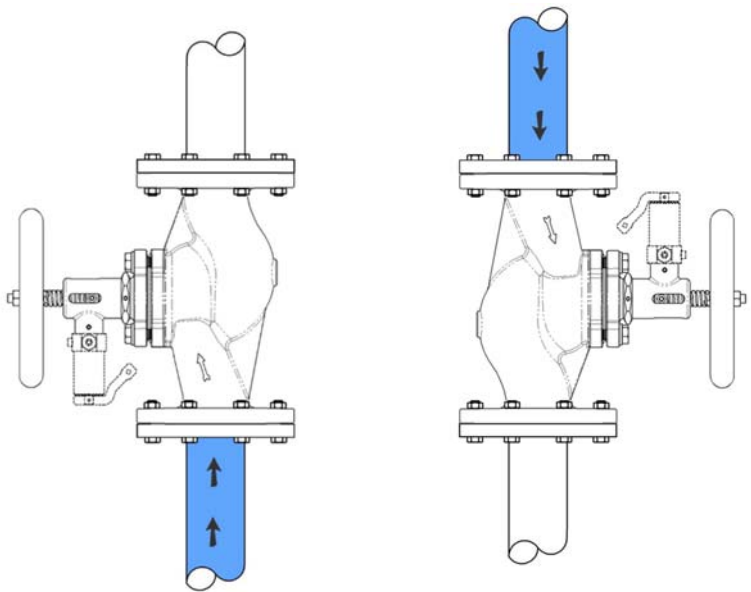
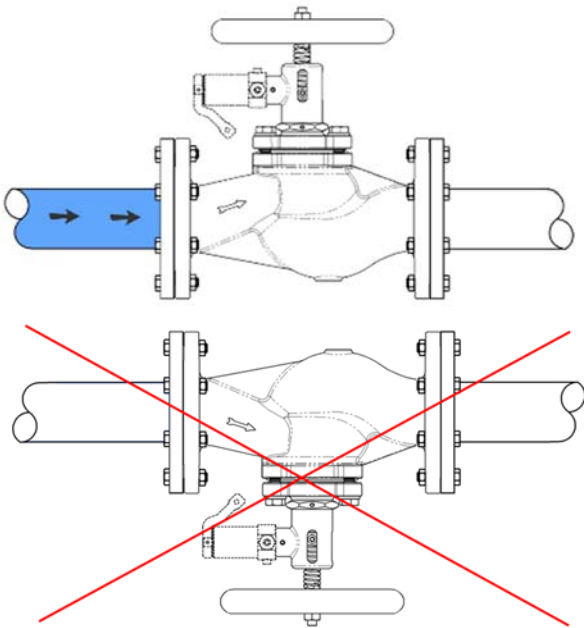

Fig.1

7.1 Installation Position

Quick closing valves must always be installed on the line with the flow direction over the disc. Valves cannot be installed with a downward-showing bonnet, in horizontal pipelines.



*Bonnet turned 90°

8. MAINTENANCE

Dikkan quick closing valves are designed to require minimum maintenance. But if you carry out the following maintenance instructions, it would be helpful to increase the longevity and reliability of valves.

 **Valves shall be dismantled from pipeline before maintenance and shall be cleaned from medium.**

 **Maintenance work must be performed by qualified, trained and skilled people according to maintenance instructions Welding is not accepted on valves repairing.**

- In very rare used places, valves should be performed open-close every 3-4 months.
- The stem threads that are exposed to the atmosphere should be periodically lubricated, with quality grease.
- Bonnet bolt tension should be checked periodically when valves are used in high temperature applications where loosening may occur. Although, leaks through ring joints are rare, erosion or corrosion could cause rings to fail. In these cases, a new ring gasket is required.
- The valve O-rings should be inspected at least monthly.

8.1 Replace the Gasket

 **Depressurize the system and remove the valve from pipeline before bonnet disassembled.**

 **Disassembled valves will become out of warranty. Please consult with Dikkan before disassembly if the valve is under warranty.**

▪ **Bonnet Disassembly**

- a) Operate the valve until it becomes to fully open position.
- b) Remove bonnet bolts (P.No17) by using crossover method.
- c) Lift up the bonnet assembly, be careful for not damaging the disc

▪ **Gasket Replacement**

- a) Discard the old gasket. (P.No4)
- b) Inspect the gasket seating surface of the body for wear, damage or deterioration.
- c) Polish gasket seating surface with sandpaper to clean rust, dirt and remnant of gasket.
- d) Clean the surface to remove all polishing residue.
- e) Install a new gasket.

▪ **Body-Bonnet Assembly**

- a) Inspect the bonnet bolts to ensure that they are not damaged. Any damaged bolts should be replaced.
- b) Place the entire bonnet assembly onto the valve body, be careful for not damaging the disc

- c) Tighten the bolts in the crossover method like a shown in Fig. 1.
- d) Test the valve as required, and place the valve back into service.

8.2 Metal to Metal Sealing

If the seat examination shows only small defects, it is possible to renew seat sealing surface lapping the seat with the special tool and immediate action is necessary.

To repair the disc seat or body seat, the valve must be removed from pipe line, by using the following procedure:

- a) Using a thick polishing paste, alternately turn clockwise and counterclockwise about 90°, softly pressing. Lift up often and turn the tool, changing its contact position with seat. Go on with lapping until any defect disappears, adding, polishing paste if necessary. And then clean the seat and repeat treatment using a thinner polishing paste.
- b) Remove lapping tool and clean carefully the seat, using a washing agent.
- c) After lapping, it is recommended that the surface of the seat and disc be checked for proper contact using marking blue. Coat the body seats with marking blue, and tightly press the disc into the body seats by hand. Remove the disc, and examine to make sure there is continuous contact between the sealing surfaces of the disc and body seat.
- d) If such contact is not homogeneous, repeat steps a, b and c until excellent contact is obtained. If the disc defect is greater, a trial to repair it can be performed by metal cutting the sealing surface of the disc on a lathe. After metal cutting perform lapping as indicated above.

8.3 Hydraulic Oil & Release Cylinder

The hydraulic oil used in the release cylinder must conform to contamination class NAS 1638-NAS9 (ISO 4406 21/18/15) in order to prevent damage to sealing elements. 10 µm filter shall be utilized in the system where the hydraulic oil is used.

Recommended hydraulic oil: Viscosity 15 - 46 cSt, (at. 40 °C approx.)

Control pressure min/max: 6 bar / 8 bar

Connection thread for pipe / pipe diameter: ISO G1/8" / Ø8

Cylinder volume: ~4.1cm³ (when the mechanism is not pulled)

~8,5cm³ (when the mechanism is pulled)

9. OPERATION

9.1 Operating Principles

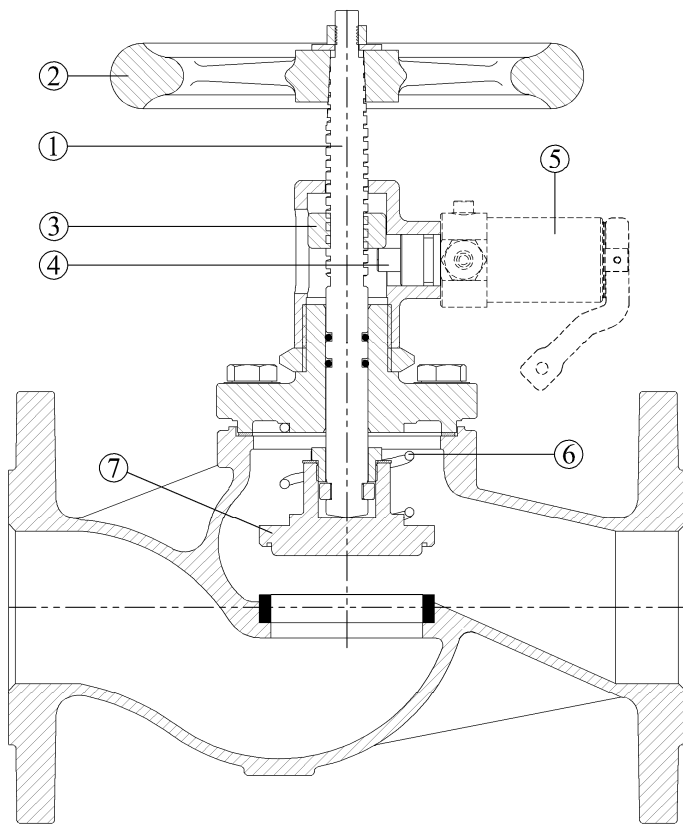

*Bonnet turned 90°

The valve is a stop valve with a remote quick closing function. A quick closing valve is in the loaded position as seen above figure. The valve ready to suddenly shut-off.

- The quick closing operation is performed by a spring (6), pre-compressed by the hand wheel.
- The stem (1) and the attached disc (7) are connected via the retainer block (3).
- When the pulling back the piston rod (4), retainer block (3) and compressed spring (6) push down the disc (7) so the valve will close.

9.2 Loading the Valve for Quick Closing

*There should not be any force on the cylinder as in 9.3.

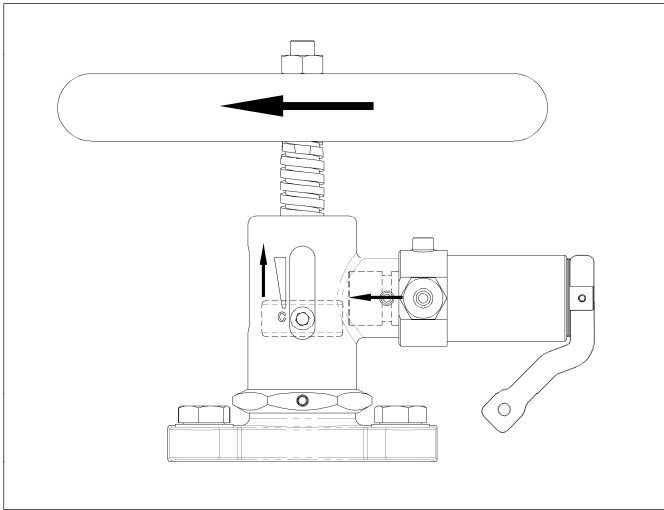

Rotate the handwheel (2) clockwise until the piston rod (4) comes out of the cylinder. As a result of this process, the retainer block (3) is fixed in the upper position.

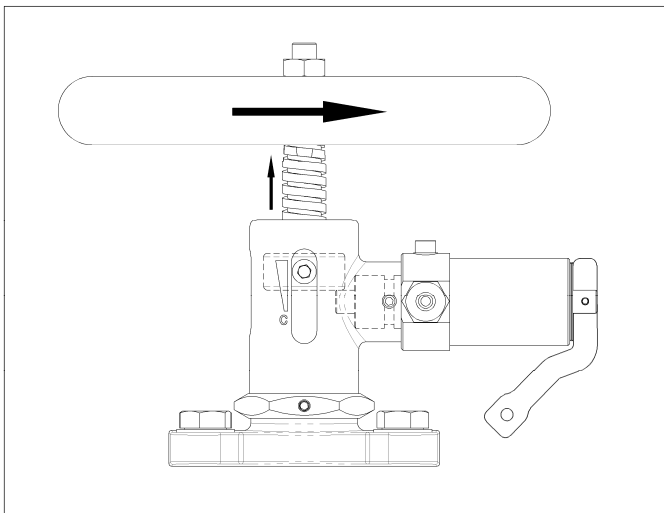

Rotate the handwheel (2) in opening direction (anticlockwise).

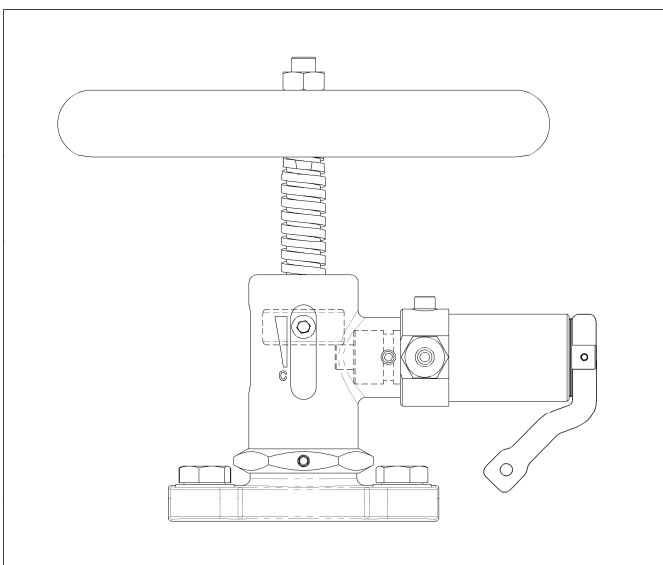

With rising of the stem, rotate the hand wheel until the thread end of the stem rests on the setting nut. At this moment, the mechanical stop is felt.

9.3 Closing of valve by the remote quick closing function

The valve is quick closed by a remote hydraulic, pneumatic or by pulling back the piston rod (4) of the release cylinder (5) by a wire arrangement.

9.4 Closing of valve by the automatic release (in case of fire)

The cylinder is equipped with a melting ring. Melting ring melts above ~180 °C and automatic release is provided by the spring.

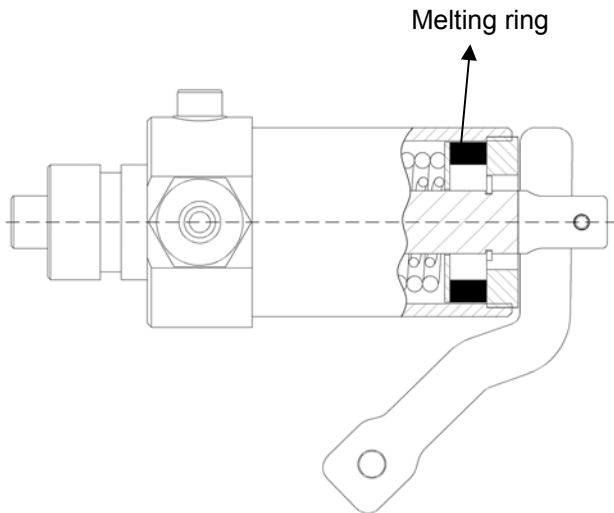

9.5 Closing valve with handwheel (optionally)

The valve can be closed by the handwheel.

Turn the hand wheel in clockwise direction (1). The setting nuts leans on the bonnet (2) and it pushes the stem down with the threaded connection (3). As a result, the valve is closed.

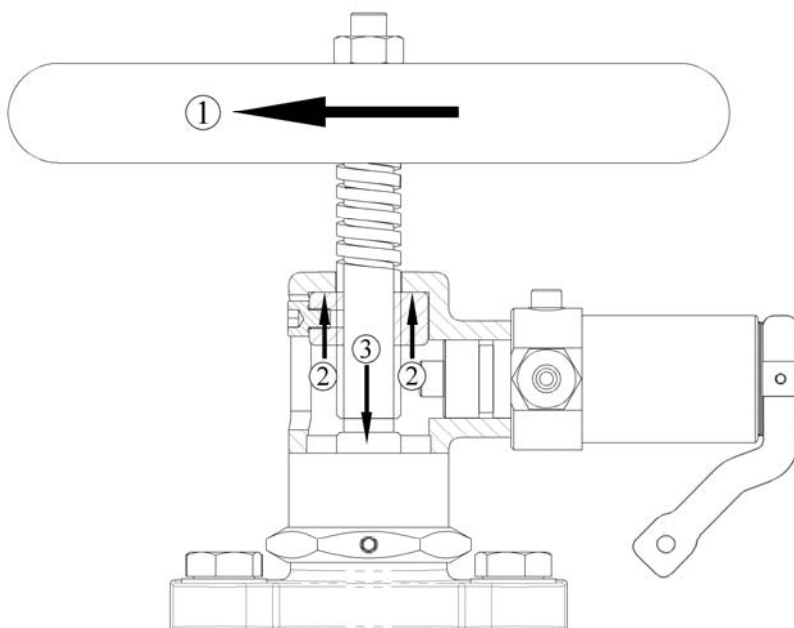

9.6 Change direction of release cylinder

The release cylinder can be turned

- Loosen the two set screws (x2)
- Rotate the release cylinder as desired
- Tighten the set screw (x2)

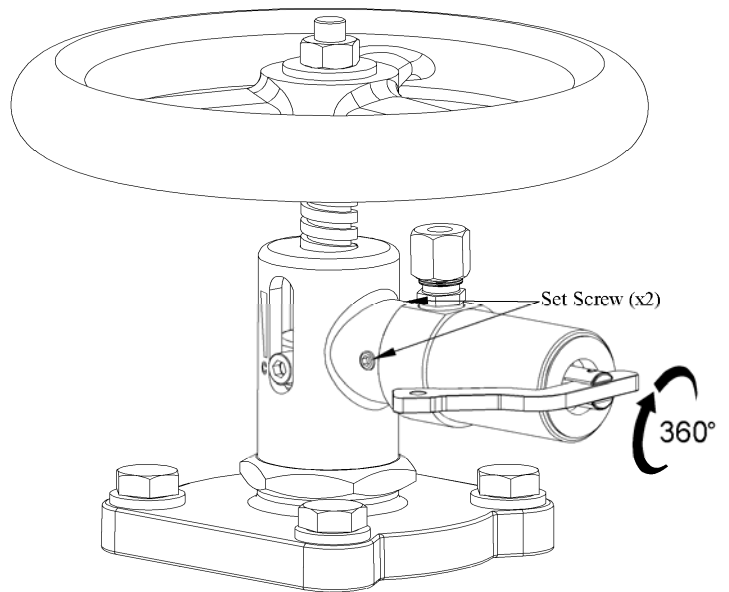

9.7 Change direction of bonnet

The bonnet can be turned

- Loosen the two set screws ^a on cylinder bonnet
- Loosen the set screw ^b on nut
- Loosen the nut
- Rotate the cylinder bonnet as desired **
- Tighten the nut
- Tighten the two set screws ^a on cylinder bonnet
- Tighten the set screw ^b on nut
- Check release cylinder is functioning

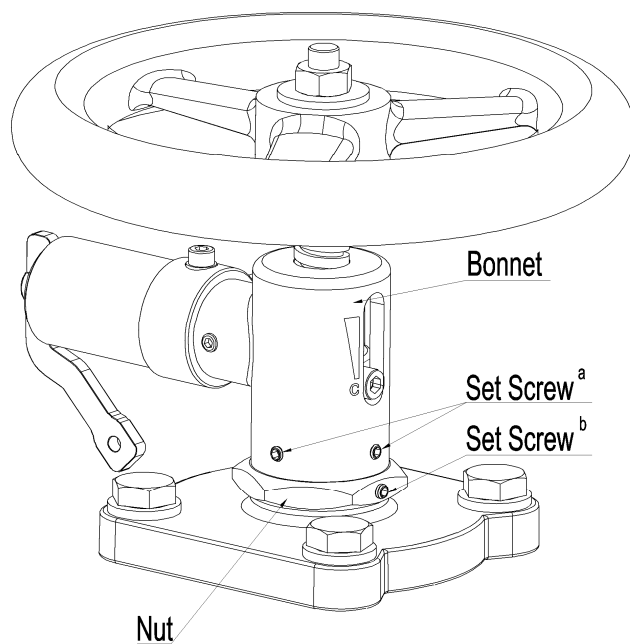

****While adjusting the direction of bonnet, cylinder bonnet is turned clockwise. It is tightened to the bottom. Then, the direction should be adjusted to return a maximum of 1 turn.**

10. RECYCLING

The product can be recycled. If suitable procedure has been respected, no environment pollution risk occurs. When the recycling of the product is made, the country's laws, rules and regulations must be observed.

11. PRESSURE EQUIPMENT DIRECTIVE (2014/68/EU) AND CE MARKING

Dikkan quick closing valves comply with the requirements of the European Pressure Equipment Directive 2014/68/EU. Valves are categorized in accordance with the maximum working pressure, size and ascending level of hazard, which is dependent on the fluid being transported. Fluids are classified as Group 1, dangerous fluids or Group 2, all other fluids including steam. Categories are SEP (sound engineering practice) and for ascending levels of hazard, I, II, III or IV. All valves designated as SEP do not bear the CE mark nor require a Declaration of Conformity. Dikkan valves with a CE marking have a declaration of conformity which includes information about the applied conformity assessment procedure. It has been confirmed that the quality assurance in design control, manufacture and the manufacturer's final acceptance of Dikkan Quick Closing Valve by a notified body.

12. SAFETY REMARKS

- The operating instruction has to be observed in an obligatory way. In the event of mismatch, all warrants and liabilities are reserved.
- Sharp edges and burrs can cause injuries.
- The valves must be mounted, started up or serviced by only fully trained and qualified personnel.
- Maintenance staff must be reminded about the dangers pertaining to disassembling and mounting of valves as well as electric and machinery installations
- Safety goggles and other appropriate protective gear should be used. Failure to do so could result in serious injury.
- All work involving valve installation in pipeline it has to be made sure that the plant is not under pressure and not medium can leak from the pipeline.
- Be sure that any dangerous or combustible or detonating gas or fluid has been depressurized from product and connected piping, to avoid any danger to maintenance people due to contact or inhalation.
- Preserve valve specific maintenance manual in conjunction with this manual and allow them to be reachable by maintenance staff. Be sure that, maintenance staff reads any parts of those manuals before any use or maintenance operation.

13. PAINTING

Nominal Dry Film Thickness (NDFT) is approximately 120 microns unless otherwise specified by the purchaser. (For coated valves)

14. TROUBLESHOOTING



Be sure to observe the safety instructions during troubleshooting.

Fault	Possible Cause	Corrective Action
Valve leaking around stem and gland	T-Bolts loose	Tighten T-Bolts
	Damaged or worn O-ring	Replace O-ring
	Damaged stem	Replace stem
Valve leaking around bonnet	Body-Bonnet bolts loose	Tighten body-bonnet bolts
	Damaged bonnet gasket	Refer to the "8.1 Replace the Gasket" sections of this manual
Valve leaking around pipe connections	Flange bolts loose	Tighten flange bolts
	Damaged flange gasket	Replace flange gasket
Valve hard operate	If the valve has not been operated over for a long time, may stem is stuck	Lubricate stem threads with grease
Valve does not pass flow	Check flow arrow direction on valve body	The arrow on the valve body must be in the same direction of the liquid flow
	Flange covers not removed	Remove flange covers
	The valves and pipeline must be protected against freezing media	Warm up pipeline system and use valve jacket
Valve seat leaking	Dirt or debris between sealing surfaces	Open valve to flush or clean sealing surfaces
	Damaged disc seat or body seat	Refer to the "8.2 Metal to Metal Sealing" sections of this manual
Low flow rate	Blockage in the pipeline system	Check pipeline system
Breaking the valve parts	Damage to the parts bearing pressure because of water hammer	To avoid water hammer, where necessary in the pipeline system, place water hammer protective equipment

15. Warranty

Warranty Period: 18 Months

The warranty does not cover maintenance work, installation of external parts. When unoriginal parts are used for replacement, warranties and liabilities become invalid.

16. NOTES

Dikkan®

Izmir Kemalpaşa Yolu

Hayıtlıkır Mevkii No:30

Kemalpaşa- IZMIR

Tel: 0090 232 877 17 14

Fax: 0090 232 877 17 15

www.dikkan.com

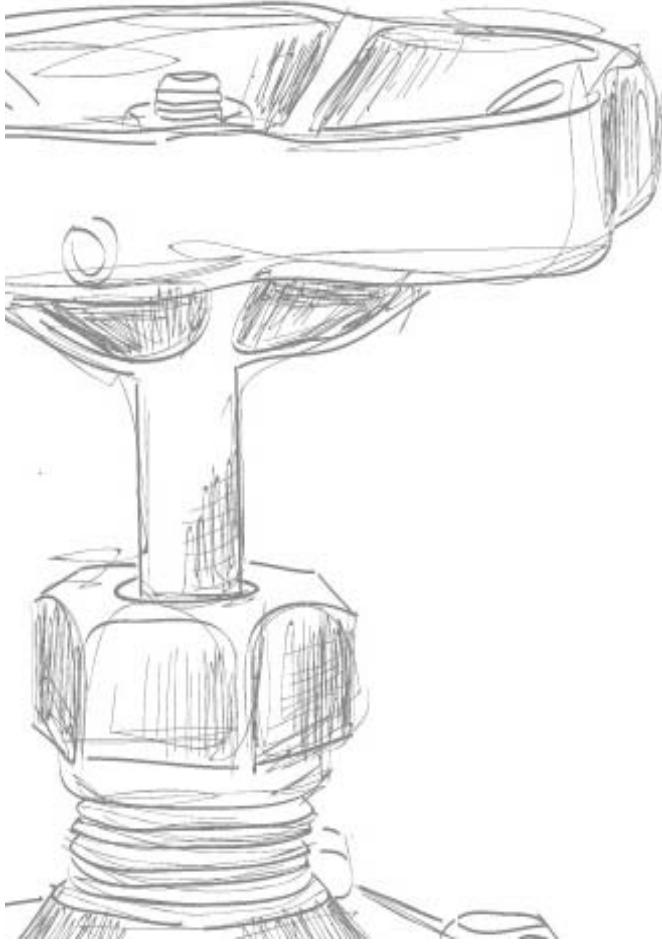

 TÜV Rheinland
Precisely Right.

 ClassNK



 Lloyd's
Register



 DNV·GL



 PG

 TÜRK LLOYD
İSTANBUL